

HORSESHOE PACKERS

POLYPROPYLENE

Application:

ALLFASTENERS' Horseshoe Packers are made from solid polypropylene. This gives them an extremely high compression strength, making them suitable for both the lightest and most heavy duty applications.

- Colour coded for easy identification of thickness.
- They will never corrode, rust, rot, shrink or expand and are guaranteed to outlast wherever they're installed.
- Our range of Horseshoe Packers will suit 99% of jobs but can be easily cut, drilled and otherwise shaped if necessary.

Ideal for window and door frame leveling, floor joist, wall and ceiling batten and joinery packing. Each packer is manufactured to the highest national standards and comes with a range of benefits.

140mm Allfasteners Horseshoe Packers

140mm Horseshoe Packers simplify wide span top hat leveling by bridging the gap between fasteners, letting you use a single packer instead of two smaller packers. This allows adjustments without the packers shifting or falling out. Suitable for common tophat and purlin structures for cladding and curtain wall construction.

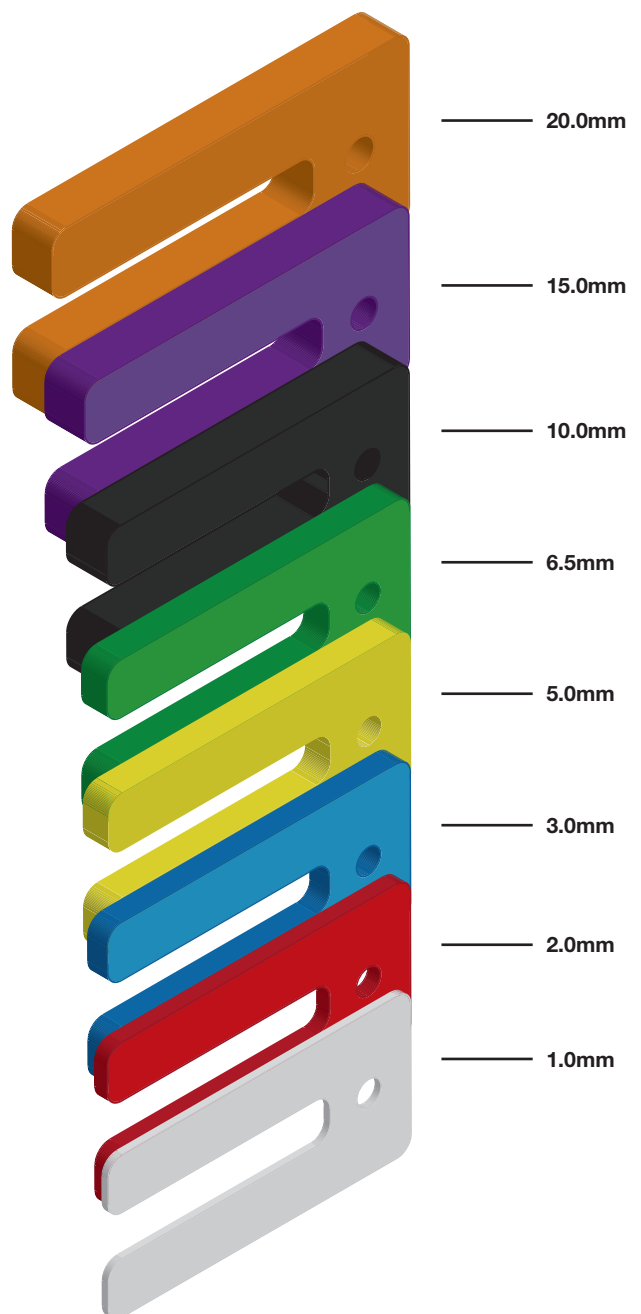
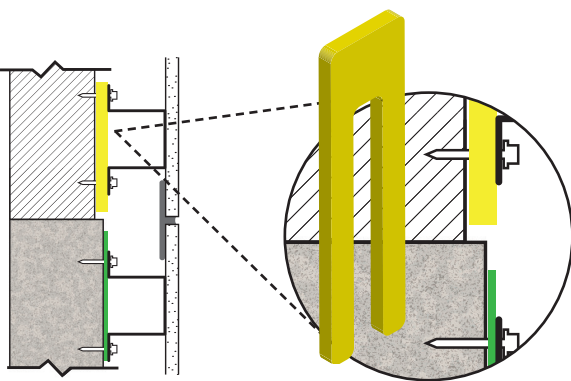
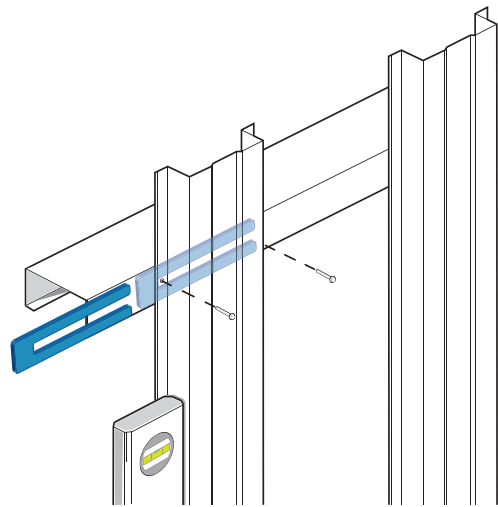

75mm Allfasteners Horseshoe Packers

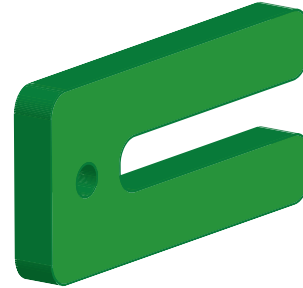
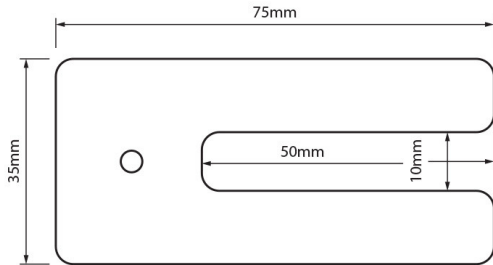

SKU	Thick (mm) x Length	Colour	Width	Box
11HP7501	1.0 x 75mm	White	35mm	4000
11HP7503	3.0 x 75mm	Blue		2000
11HP7505	5.0 x 75mm	Yellow		1600
11HP7506	6.5 x 75mm	Green		1000
11HP7510	10.0 x 75mm	Black		600
11HP7515	15.0 x 75mm	Purple		400
11HP7520	20.0 x 75mm	Orange		300

140mm Allfasteners Horseshoe Packers

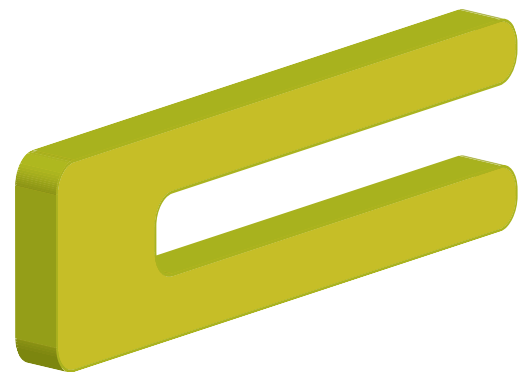
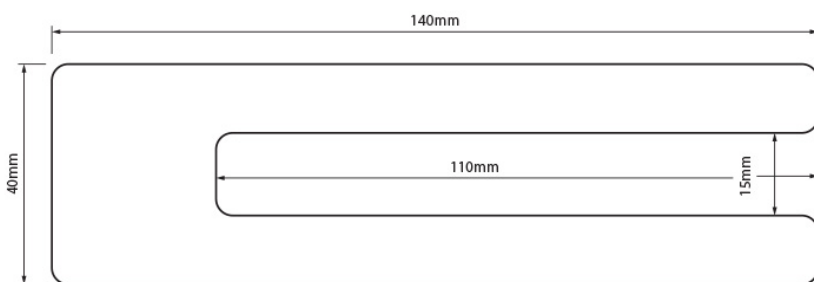

SKU	Thick (mm) x Length	Colour	Width	Box
11HP14001	1.0 x 140mm	White	40mm	2500
11HP14002	2.0 x 140mm	Red		1200
11HP14005	5.0 x 140mm	Yellow		600
11HP14010	10.0 x 140mm	Black		300
11HP14015	15.0 x 140mm	Purple		200
11HP14020	20.0 x 140mm	Orange		150

HORSESHOE PACKERS
POLYPROPYLENE

90mm Square Allfasteners Horseshoe Packers

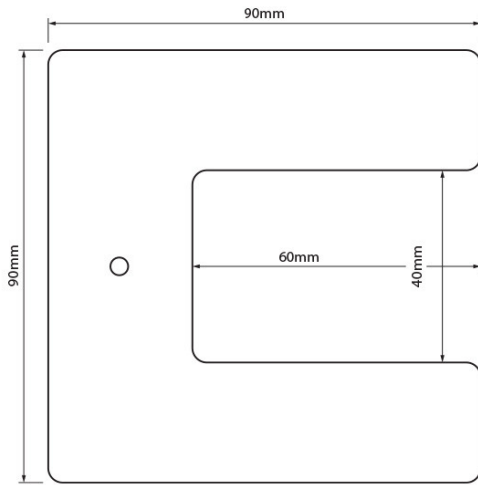

SKU	Thick (mm) x Length	Colour	Width	Box
11HP9001	1.0 x 90mm	White	90mm	1500
11HP9002	2.0 x 90mm	Red		700
11HP9003	3.0 x 90mm	Blue		500
11HP9005	5.0 x 90mm	Yellow		300
11HP9010	10.0 x 90mm	Black		150

90mm Allfasteners Horseshoe Packers

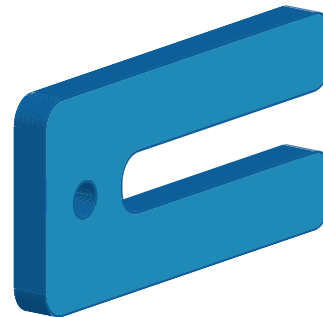
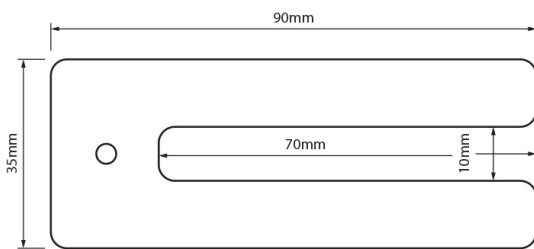

SKU	Thick (mm) x Length	Colour	Width	Box
11HP903501	1.0 x 75mm	White	35mm	4000
11HP903502	3.0 x 75mm	RED		2000
11HP903503	5.0 x 75mm	Yellow		1600
11HP903505	6.5 x 75mm	Green		1000
11HP903510	10.0 x 75mm	Black		600

**TECHNICAL DATA****Compressive Strength****ASTM D695-02a : Standard Test Method for Compressive Properties of Rigid Plastics.**

Each material sample was subjected to a load capacity of 100kN, the materials change* in form was then measured.

SAMPLE	1.5 mm	3 mm	5 mm	6.5 mm	10 mm
Mean Change	0.09 mm	0.21 mm	0.45 mm	0.38 mm	0.65 mm

*Change in material expressed a mean of samples tested in each group.

UV Stabilisation

Product Code: AD030615A

Colour Name: UV Additive

Carrier: PE

Addition Rate: 1.00%

Description: This Masterbatch is based on LLDPE carrier, It contains HALS type UV additive for protection of plastic products and it is suitable for the application of Injection Moulding, Blow Moulding and Extrusion of Polyolefines.

Packaging: The Masterbatch is normally supplied in 15kg polyethylene bags.

Properties	Values
Granules:	2-3 mm (Approx)
UV additives Content:	>20%
Heat Stability:	270°C (additive only)
Light Fastness:	N/A (Blue Wool Scale)
Food Contact:	Yes (AS2070-1999)