

CS-ZD

DYNAMIC CONICAL CHEM STUD / ZINC PLATED / FATIGUE RATED

CERTIFICATION

TDS

FIRE REPORT

ZP

Technical Data Sheet

- High performance anchor
- Approved for cracked and uncracked concrete
- ETA fatigue rated
- C1 & C2 seismic rated

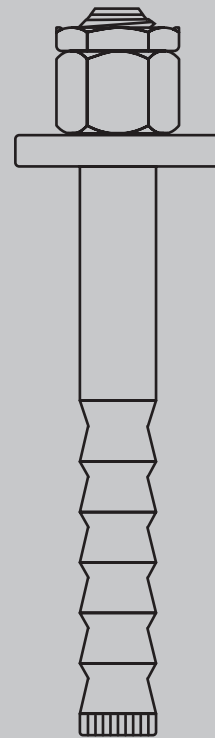

For Install Support

techadvice@allfasteners.com.au



For Specification Support

engineering@allfasteners.com.au



For Customer Support

1800 255 349



CS-ZD

DYNAMIC CONICAL CHEM STUD / ZINC PLATED / FATIGUE RATED

CS-ZD

Dynamic Conical Chem Stud,
Zinc Plated, Fatigue Rated



- High performance chemical anchor for dynamic loading including fatigue and seismic
- Heavy duty fastenings with alternating loads and infinite number of cycles — cranes, industrial robots, antenna towers, noise barriers, elevators
- No strength reduction for wet or water-filled holes
- Through-set and pre-set installation for flexible application
- Zinc plated ($\geq 5\mu\text{m}$) for dry internal conditions

AS 5216 Compliant

ETA Cracked and Uncracked Concrete

ETA Fatigue Rated

C1 & C2 Seismic Rated

F30 - F120 Fire Rated

French VOC A+ Rated

Supported by AFOS Anchor Design Software

Anchor Summary

CS-ZD with CS-D Chemical Injection

Part Number	Description, Dia x L	Min. - Max. Fixture Thickness, $t_{fix}^{1)}$	Effective Embedment Depth, h_{ef}	Drill Dia, d_o	Drill Hole Depth, h_o	Minimum Concrete Thickness, h_{min}	Seismic C1/C2	Design Capacity in 32MPa Cracked Concrete ²⁾		Indicative Price Per Fixing ³⁾
								Tension	Shear	
1006.0120160	M12 x 160mm	12 - 25mm	100mm	14mm	130mm - t_{fix}	130mm	✓ / ✓	29.0kN	27.2kN	\$27.30
1006.0120185	M12 x 185mm	12 - 50mm			155mm - t_{fix}					
1006.0160200	M16 x 200mm	16 - 30mm	125mm	18mm	163mm - t_{fix}	160mm	✓ / ✓	40.5kN	50.4kN	\$35.08
1006.0160220	M16 x 220mm	16 - 50mm			183mm - t_{fix}					
1006.0200280	M20 x 280mm	20 - 50mm	170mm	24mm	230mm - t_{fix}	220mm	✓ / ✓	64.3kN	119.2kN	\$69.76
1066.4200001	CS-D 420ml Chemical Injection									

1) Fixture thickness (t_{fix}) must be within the minimum and maximum fixture thickness limits.

2) Without concrete edge or anchor spacing influence. Static and quasi-static load such as wind. To consider all design inputs and details, please refer to our AFOS Anchor Design Software or the ETA.

3) Based on a volume of 200+ to 500+ fixings, 96+ chemical tubes, as of March 2026. Includes cost of chemical, stud, nut and washer.

Application Times

Temp. (°C) ¹⁾	-15° to -10°	-9° to -5°	-4° to -1°	0° to 4°	5° to 9°	10° to 19°	20° to 29°	30° to 34°	35° to 39°	40°
Working (mins.)	45'			20'	12'	6'	4'	2'	1.4'	
Cure (mins.) ²⁾	7d	10.5hrs	6hrs	180'	120'	80'	45'	25'	20'	15'

1) Base material temperature. Cartridge and outside temperature when installing must be at least +5°C. It must be ensured that icing does not occur in the drill hole.

2) Minimum curing time in dry concrete. Double the curing time for wet concrete.

Service temperature: -40°C to +80°C

CS-ZD

DYNAMIC CONICAL CHEM STUD / ZINC PLATED / FATIGUE RATED

Fatigue Design

For assistance with fatigue design, please contact Allfasteners. This will be covered by the new version of AS 5216, however currently EN 1992-4 and EOTA TR-061 provide guidance, as well as AEFAC TN14.

Installation Parameters

Anchor Size			M12	M16	M20
Effective embedment depth	h_{ef}	[mm]	100	125	170
Drill hole diameter	d_o	[mm]	14	18	24
Depth of drill hole ¹⁾	$h_o \geq$	[mm]	105	130	180
Diameter of clearance hole in fixture	$d_f \leq$	[mm]	15	19	25
Minimum thickness of fixture	$t_{fix, min}$	[mm]	12	16	20
Overstand	h_p	[mm]	$31 + t_{fix}$	$39 + t_{fix}$	$48 + t_{fix}$
Installation torque	T_{inst}	[Nm]	30	50	80
Width across nut	SW	[mm]	19	24	30
Minimum thickness of concrete member	h_{min}	[mm]	130	160	220
Minimum spacing (cracked concrete)	s_{min}	[mm]	50	60	80
Minimum edge distance (cracked concrete) ²⁾	c_{min}	[mm]	70 (50)	80 (60)	110 (80)
Minimum spacing (uncracked concrete)	s_{min}	[mm]	80	60	80
Minimum edge distance (uncracked concrete)	c_{min}	[mm]	75	80	110

1) If the fixture thickness is lower than the maximum fixture thickness of the anchor, the depth of drill hole has to be increased accordingly.

2) Values in brackets are valid only if 8mm diameter edge reinforcement is installed.

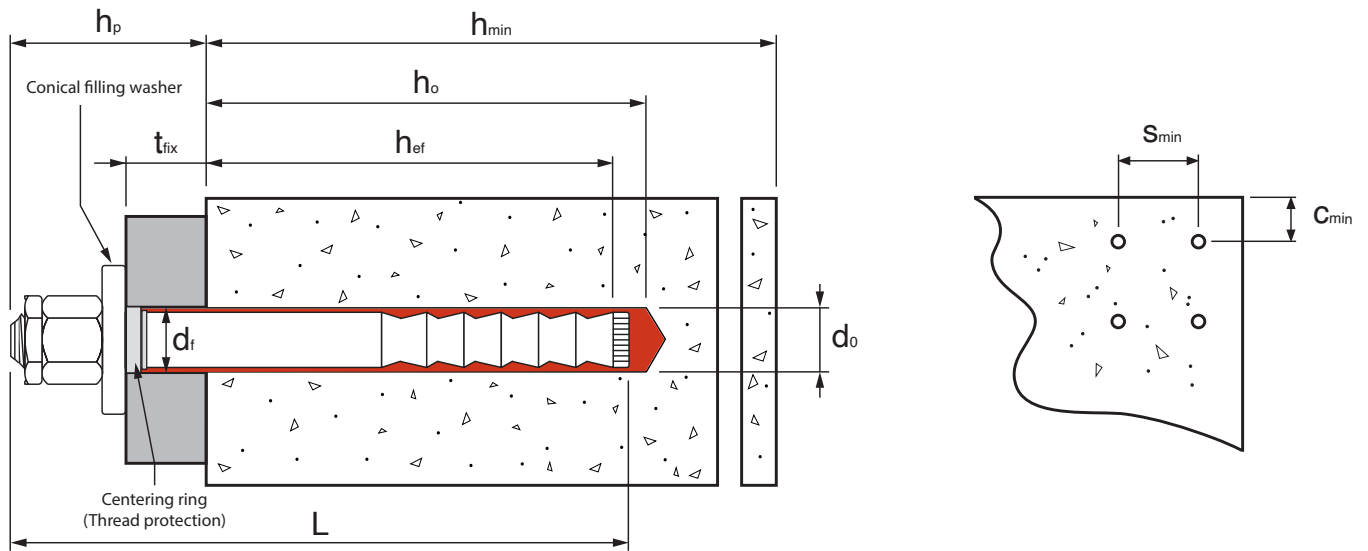

Through-set installation

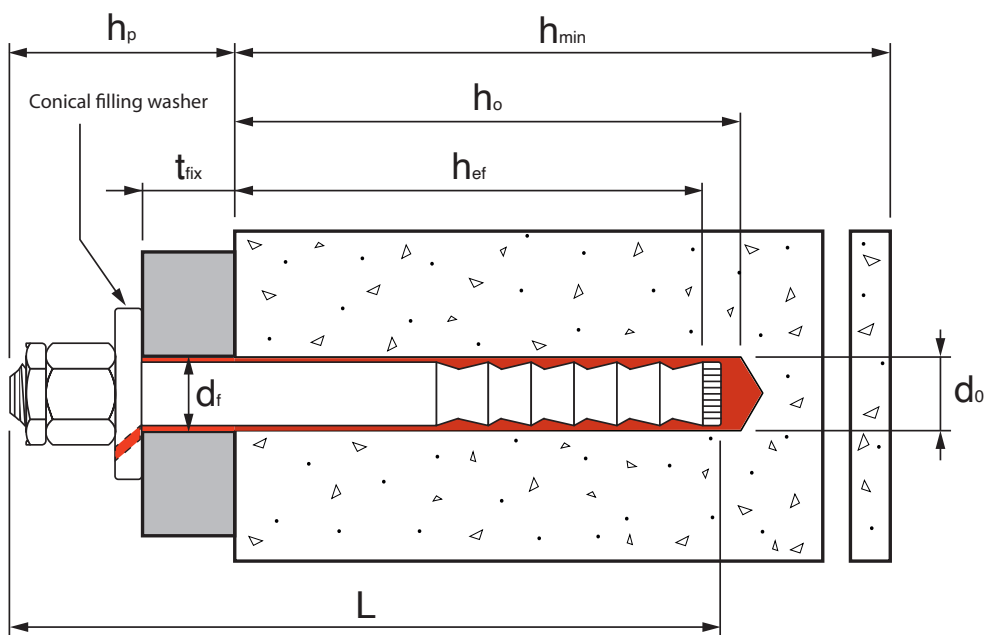

Pre-set installation

Note: Remove the plastic centering thread protection ring for pre-set installation.



Installation Instructions: Through-set Installation

Cleaning with compressed air			Inject Chemical		
1		Drill hole perpendicular to concrete surface with hammer drill, compressed air drill or vacuum drill bit.	5		Check minimum shelf-life on CS-D Chemical Injection cartridge. Never use when expired. Remove cap from cartridge, and screw static mixer on cartridge. When using a new cartridge always use a new static mixer.
2		Connect air blower to compressed air (min. 6bar, oil-free). Blow out dust from drill hole along the entire depth with back and forth motion at least 2 times .	6		Insert cartridge in dispenser. Before injecting, discard adhesive (at least 2 full strokes or a line of 10cm) until it shows a consistent grey colour. Never use this adhesive.
3		Check diameter of cleaning brush. If brush can be pushed into drill hole without any resistance, it must be replaced. Brush drill hole back and forth along the entire drill hole depth at least 2 times while rotated by drill machine.	7		Before injection, ensure the static mixer reaches the drill hole bottom; use mixer extension if needed. Fill from the bottom up to avoid air pockets.
4		Connect air blower to compressed air (min. 6bar, oil-free). Blow out dust from drill hole along the entire depth with back and forth motion at least 2 times .	Install chem stud		
Manual cleaning (Alternative cleaning method)			8		Insert the pre-assembled anchor by hand within the working time, rotating slightly up to full depth, until the washer contacts the fixture. The anchor is properly set when the annular gap between the stud and fixture is fully filled. If not filled, remove, let cure, drill hole and restart from step 2.
1		Drill hole perpendicular to concrete surface with hammer drill, compressed air drill or vacuum drill bit.	9		Follow minimum curing time shown in Application Times table. During curing time anchor must not be moved or loaded.
2		Blow out dust from the bottom of the hole at least 2 times .	10		Remove excess adhesive after curing time. And remove lock nut.
3		Check diameter of cleaning brush. If brush can be pushed into drill hole without any resistance, it must be replaced. Brush drill hole back and forth along the entire drill hole depth at least 2 times while rotated by drill machine.	11		Apply installation torque T_{inst} by using a calibrated torque wrench. Screw on lock nut until hand tight then tighten 1/4 to 1/2 turn using a screw wrench.
4		Blow out dust from the bottom of the hole at least 2 times .			

Note:

Manual cleaning is permitted for fixings with chem studs size M12 and M16.

Installation Instructions: Pre-set Installation

Cleaning with compressed air			Inject chemical		
1		Drill hole perpendicular to concrete surface with hammer drill, compressed air drill or vacuum drill bit.	5		Check minimum shelf-life on CS-D Chemical Injection cartridge. Never use when expired. Remove cap from cartridge, and screw static mixer on cartridge. When using a new cartridge always use a new static mixer.
2		Connect air blower to compressed air (min. 6bar, oil-free). Blow out dust from drill hole along the entire depth with back and forth motion at least 2 times .	6		Insert cartridge in dispenser. Before injecting, discard adhesive (at least 2 full strokes or a line of 10cm) until it shows a consistent grey colour. Never use this adhesive.
3		Check diameter of cleaning brush. If brush can be pushed into drill hole without any resistance, it must be replaced. Brush drill hole back and forth along the entire drill hole depth at least 2 times while rotated by drill machine.	7		Before injection, ensure the static mixer reaches the drill hole bottom; use mixer extension if needed. Fill from the bottom up to avoid air pockets.
4		Connect air blower to compressed air (min. 6bar, oil-free). Blow out dust from drill hole along the entire depth with back and forth motion at least 2 times .	Install chem stud		
Manual cleaning (Alternative cleaning method)			8		Mark embedment depth. Insert the anchor by hand with slight rotation within the working time. The anchor is properly set when excess adhesive seeps out. If not filled, remove, let cure, drill hole and restart from step 2.
1		Drill hole perpendicular to concrete surface with hammer drill, compressed air drill or vacuum drill bit.	9		Follow minimum curing time shown in Application Times table. During curing time anchor must not be moved or loaded.
2		Blow out dust from the bottom of the hole at least 2 times .	10		Remove excess adhesive after curing time.
3		Check diameter of cleaning brush. If brush can be pushed into drill hole without any resistance, it must be replaced. Brush drill hole back and forth along the entire drill hole depth at least 2 times while rotated by drill machine.	11		Install fixture, washer and nut (without centring ring). Apply installation torque T_{inst} by using a calibrated torque wrench. Screw on lock nut until hand tight then tighten 1/4 to 1/2 turn using a screw wrench.
4		Blow out dust from the bottom of the hole at least 2 times .	12		Fill the annular gap between anchor and fixture with adhesive through the bore of the conical washer using the adapter plugged onto the static mixer. The annular gap is properly filled when excess adhesive seeps out.

Note:

Manual cleaning is permitted for fixings with chem studs size M12 and M16.

For other anchor properties, please refer to the ETA on our website.



CS-ZD

DYNAMIC CONICAL CHEM STUD / ZINC PLATED / FATIGUE RATED



AFOS[®]
Anchor Design Software

DOWNLOAD

allfasteners.com.au/afos

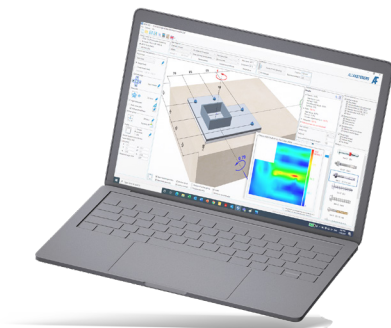

Important Note: Whilst all reasonable care is taken in compiling technical data on the Company's products, all information, recommendations, or suggestions regarding the use of such products are made without guarantee, since the conditions of use are beyond the control of the Company. It is the customer's responsibility to satisfy himself that each product is fit for the purpose for which he intends to use it, that the actual conditions of use are suitable, and that in the light of our continual research and development programme the information relating to each product has not been superseded. Allfasteners, its agencies and employees, disclaim any and all liability in respect of anything or the consequences of anything done or omitted to be done in reliance upon the whole or any part of this document.

Allfasteners[®] 78-84 Logistics Street Keilor Park VIC 3042 Australia +61 3 9330 0555 Allfasteners Pty Ltd. ACN 113 948 100 ABN 86 766 075 300
Copyright © 2026. The contents of this document remains the property of Allfasteners[®] and may not be reproduced without prior written permission.